

Features

- Synchronous Controller in 8-Pin Package
- Operating with single 5V or 12V supply voltage
- Internal 200KHz Oscillator (400KHz for AP2014A)
- Soft-Start Function
- Fixed Frequency Voltage Mode
- 500mA Peak Output Drive Capability
- Protects the output when control FET is shorted
- SOP-8L Pb-Free package
- Lead Free Finish/RoHS Compliant for Lead Free products (Note 1)

General Description

The AP2014 controller IC is designed to provide a low cost synchronous Buck regulator for on-board DC to DC converter applications. With today's ASIC products requiring supply voltages at 1.8V and lower, when the output current is as much as 3A and the input voltage is at either 3.3V or 5V, traditional linear regulator simply incurs too much loss within itself. The AP2014 together with dual N-channel MOSFETs provide a low cost solution for such applications. This device features an internal 200KHz oscillator (400KHz for "A" version), under-voltage lockout for both Vcc and Vc supplies, an external programmable soft-start function as well as output under-voltage detection that latches off the device when an output short is detected.

Applications

- Graphic Card
- Hard Disk Drive
- DDR memory source sink Vtt application
- Low cost on-board DC to DC such as 5V to 3.3V, 2.5V or 1.8V

Ordering Information

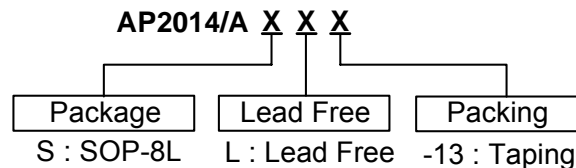

Note: 1. RoHS revision 13.2.2003. Glass and High Temperature Solder Exemptions Applied, see *EU Directive Annex Notes 5 and 7*.

Device	Package Code	Packaging (Note 2)	13" Tape and Reel	
			Quantity	Part Number Suffix
AP2014/AS	S	SOP-8L	2500/Tape & Reel	NA

Note: 2. Pad layout as shown on Diodes Inc. suggested pad layout document AP02001, which can be found on our website at <http://www.diodes.com/datasheets/ap02001.pdf>.

Pin Assignment

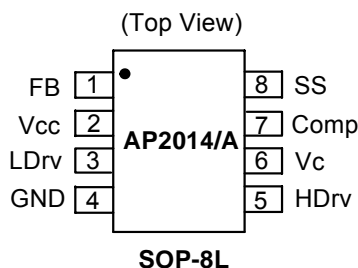

Pin Descriptions

Pin Name	Pin No.	Description
FB	1	This pin is connected directly to the output of the switching regulator via resistor divider to provide feedback to the Error amplifier.
Vcc	2	This pin provides biasing for the internal blocks of the IC as well as power for the low side driver. A minimum of 1uF, high frequency capacitor must be connected from this pin to ground to provide peak drive current capability.
LDrv	3	Output driver for the synchronous power MOSFET.
GND	4	This pin serves as the ground pin and must be connected directly to the ground plane. A high frequency capacitor (0.1 to 1uF) must be connected from V5 and V12 pins to this pin for noise free operation.
HDrv	5	Output driver for the high side power MOSFET.
Vc	6	This pin is connected to a voltage that must be at least 4V higher than the bus voltage of the switcher (assuming 5V threshold MOSFET) and powers the high side output driver. A minimum of 1uF, high frequency capacitor must be connected from this pin to ground to provide peak drive current capability.
Comp	7	Compensation pin of the error amplifier. An external resistor and capacitor network is typically connected from this pin to ground to provide loop compensation.
SS	8	This pin provides soft-start for the switching regulator. An internal current source charges an external capacitor that is connected from this pin to ground which ramps up the output of the switching regulator, preventing it from overshooting as well as limiting the input current. The converter can be shutdown by pulling this pin below 0.5V.

Block Diagram

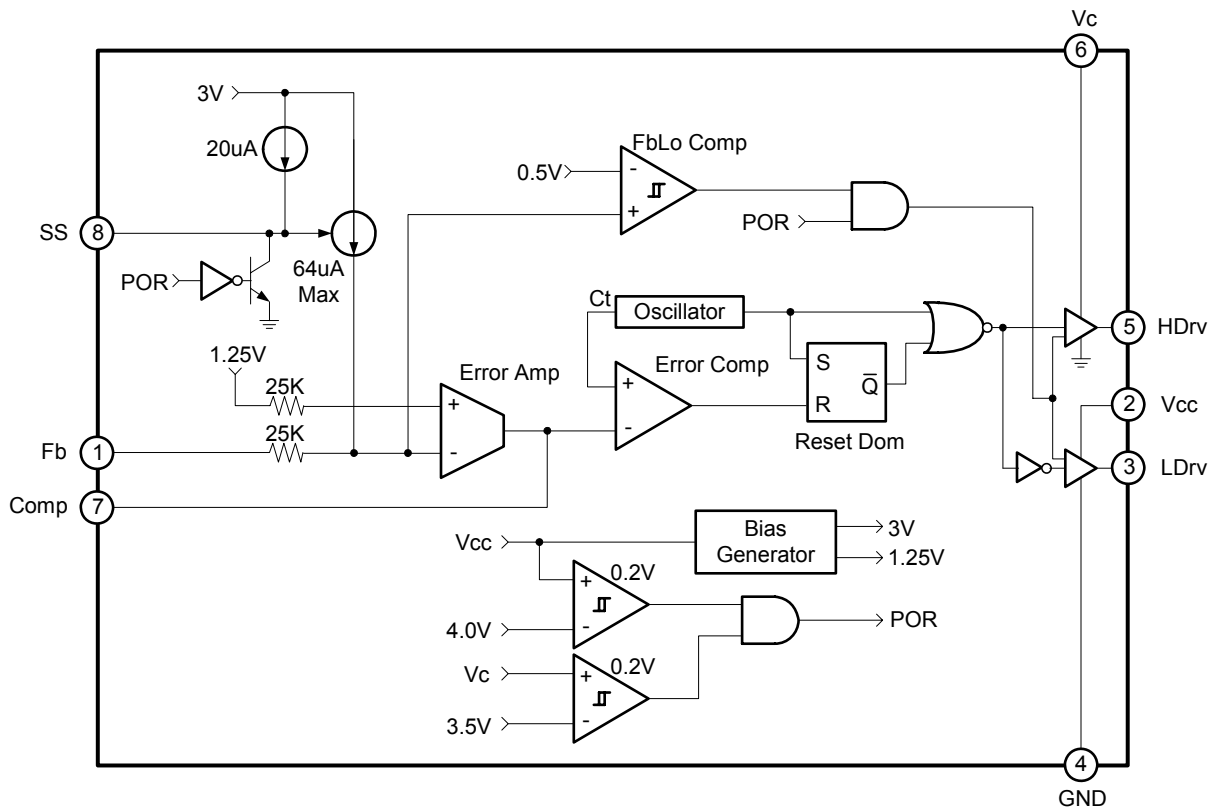

Typical Application Circuit

(1)

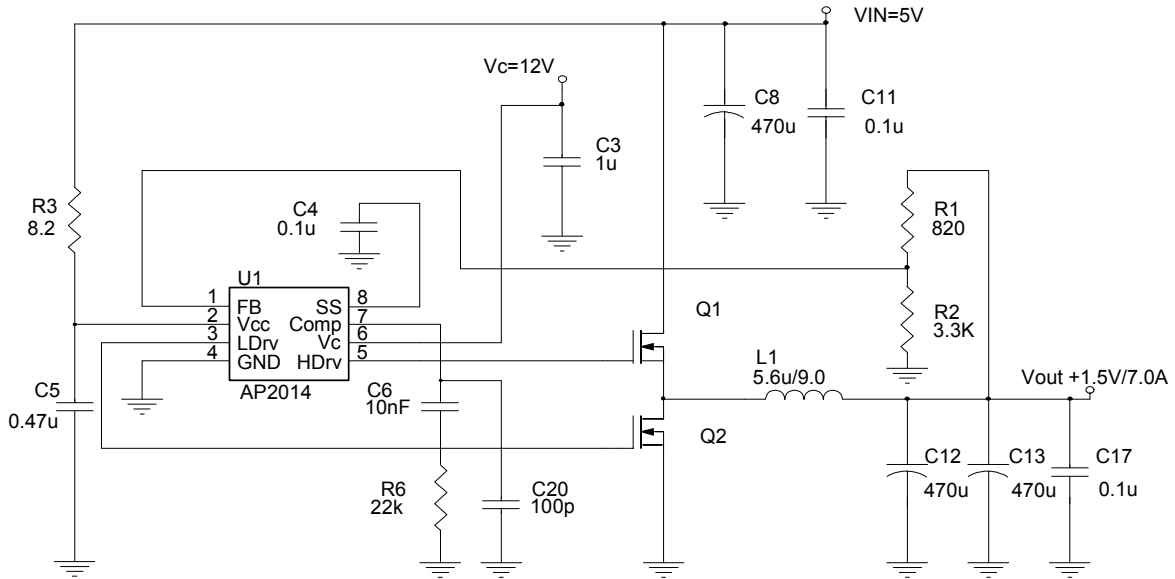

(2)

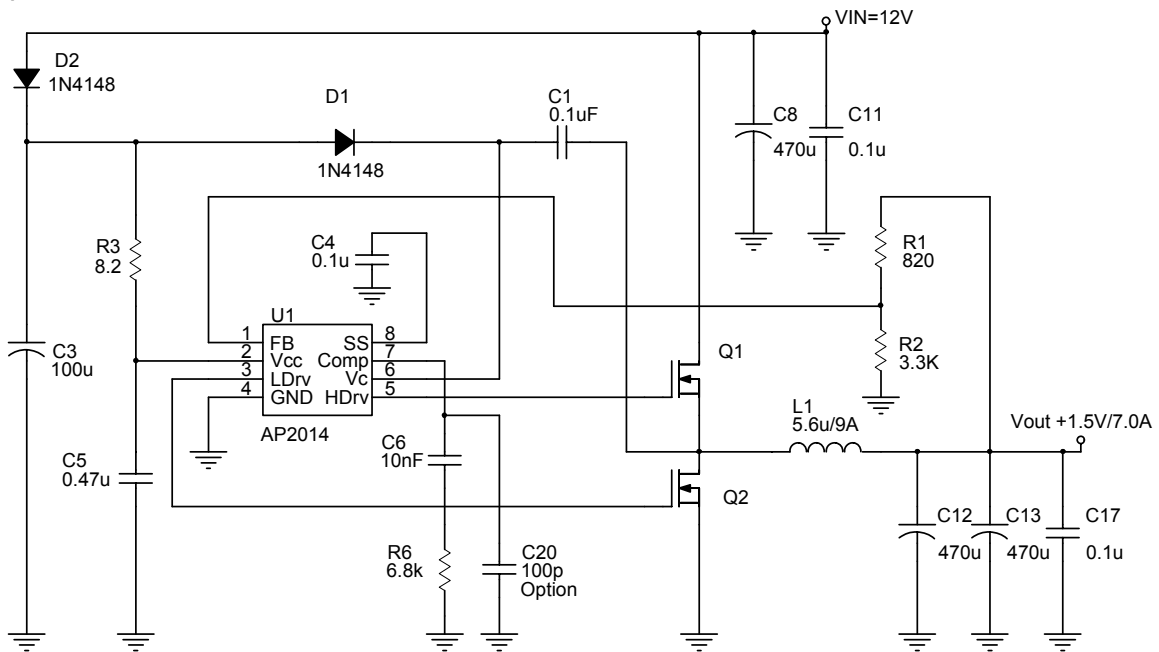

Single Supply 12V Input

Typical Application Circuit (Continued)

(3)

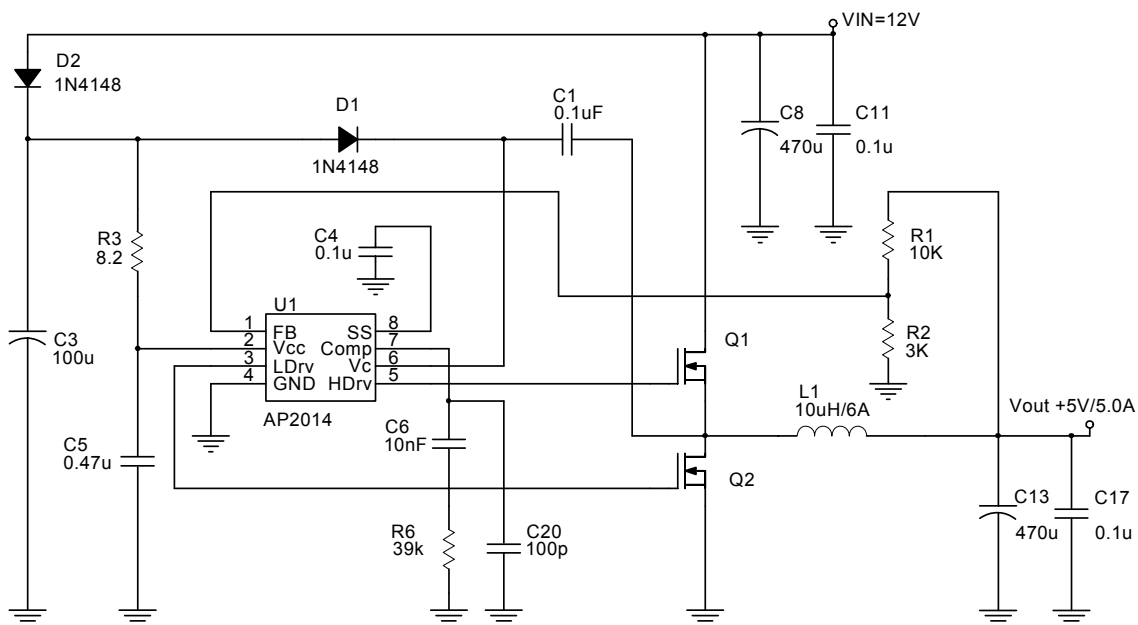

Single Supply 12V Input

(4)

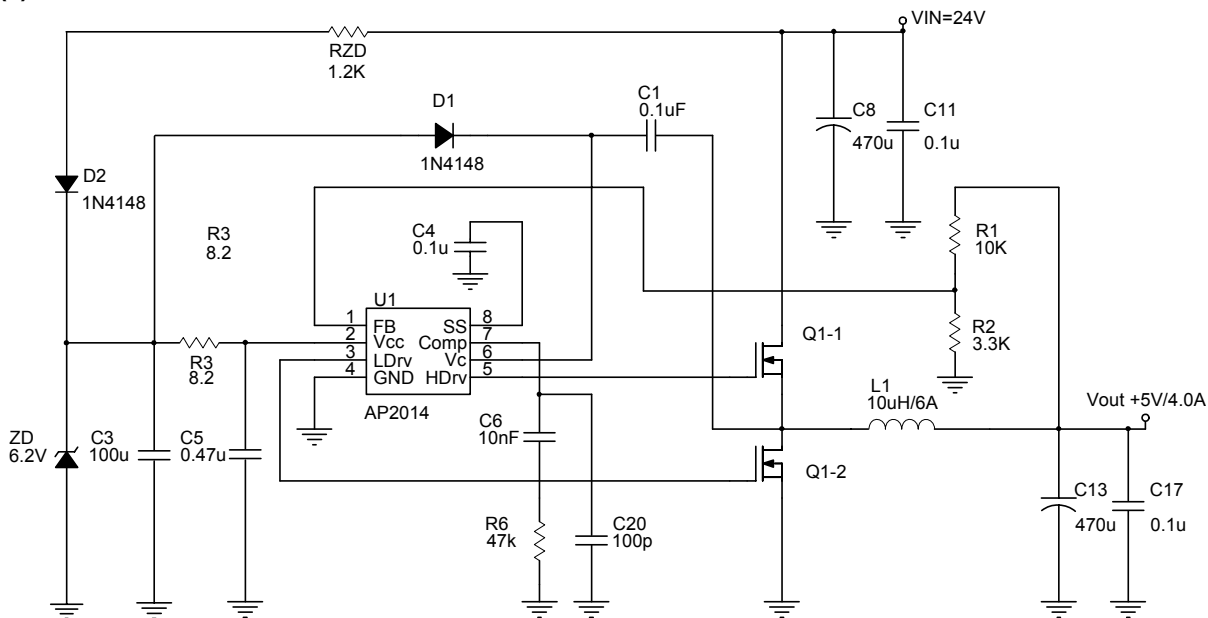

$$I_{ZD} (\geq 15mA) = (V_{IN} - V_{D2} - V_{ZD}) / R_{ZD}$$

Single Supply 24V Input

Typical Application Circuit (Continued)

(5)

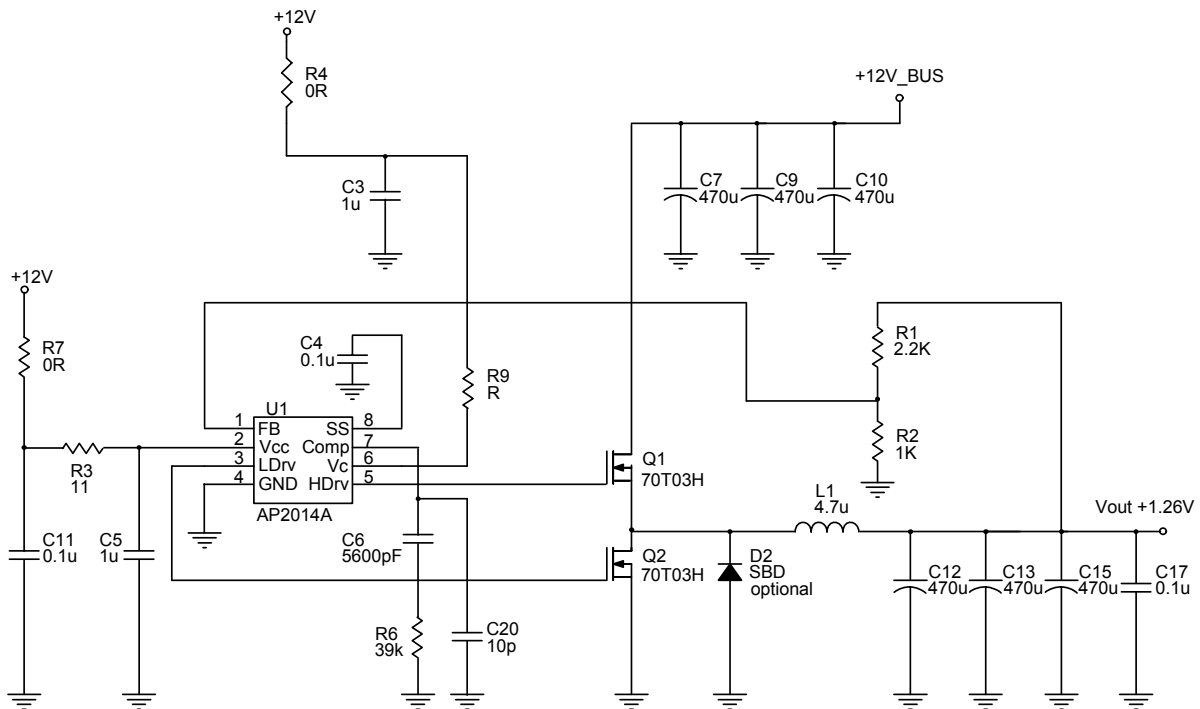

Typical Application Circuit (Continued)

(6) Dual Supply, 5V Bus and 12V Bias Input

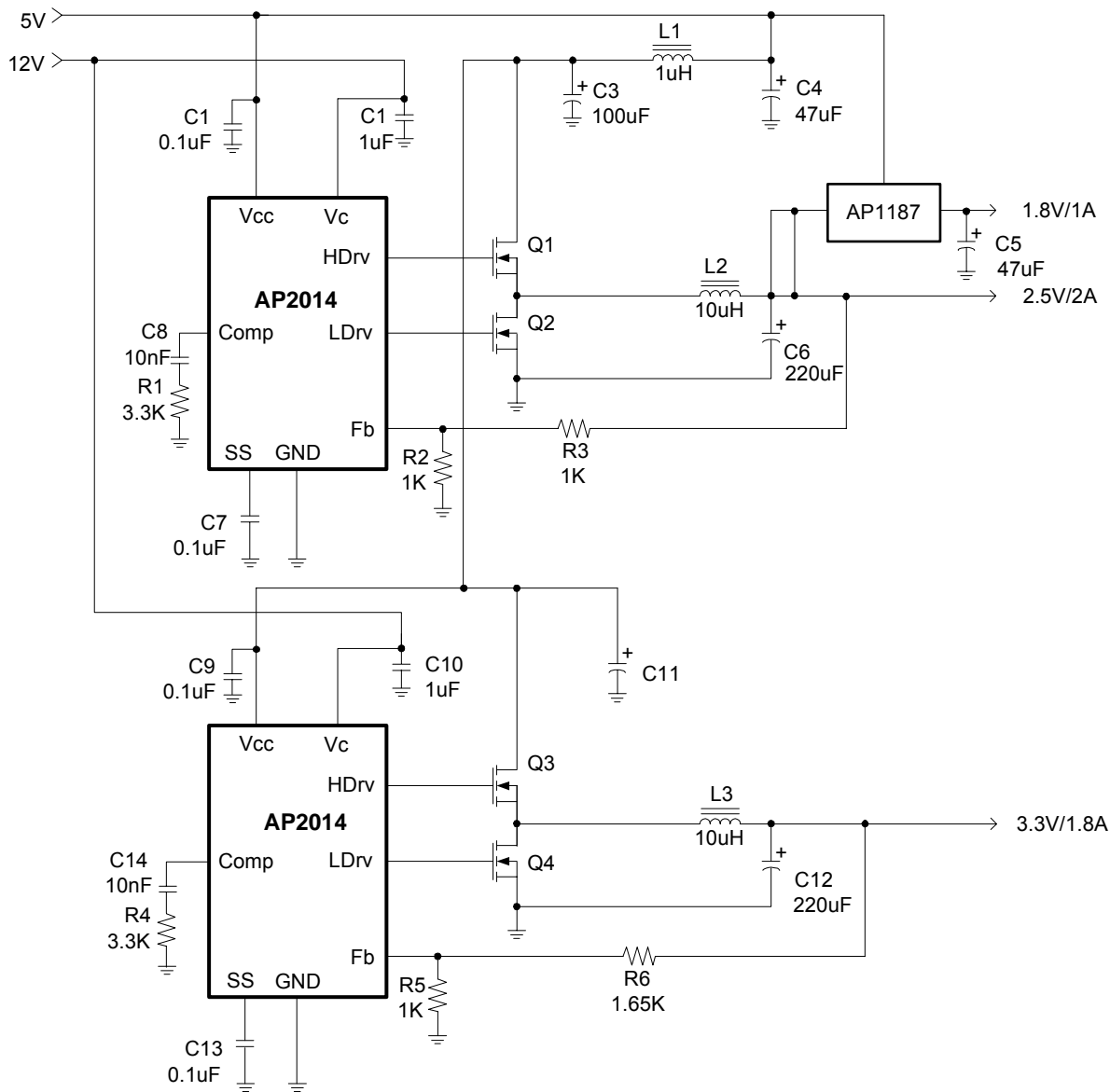

Dual Supply, 5V Bus and 12V Bias Input

Absolute Maximum Ratings

Symbol	Parameter	Rating	Unit
V _{CC}	V _{CC} Supply Voltage	20	V
V _C	V _C Supply Voltage (not rated for inductive load)	32	V
T _{ST}	Storage Temperature Range	-65 to +150	°C
T _{OP}	Operating Junction Temperature Range	0 to +125	°C
θ _{JC}	Thermal Resistance Junction to Case	7	°C/W
θ _{JA}	Thermal Resistance Junction to Ambient	160	°C/W

Note: 3. Test conditions for SOP-8L: Device mounted on 2oz copper, minimum recommended pad layout, FR-4 PCB.

Electrical Characteristics

Unless otherwise specified, these specifications apply over V_{CC}=5V, V_C=12V and T_A=0 to 70°C. Typical values refer to T_A=25°C. Low duty cycle pulse testing is used which keeps junction and case temperatures equal to the ambient temperature.

Symbol	Parameter	Conditions	Min.	Typ.	Max.	Unit
Reference Voltage						
V _{FB}	FB Voltage	AP2014	1.225	1.25	1.275	V
		AP2014A	0.784	0.800	0.816	
L _{REG}	FB Voltage Line Regulation	5 < V _{CC} < 12	-	0.2	0.35	%
UVLO						
UVLO V _{CC}	UVLO Threshold - V _{CC}	Supply Ramping Up	4.0	4.2	4.4	V
	UVLO Hysteresis - V _{CC}		-	0.25	-	V
UVLO V _C	UVLO Threshold - V _C	Supply Ramping Up	3.1	3.3	3.5	V
	UVLO Hysteresis - V _C		-	0.2	-	V
UVLO FB	UVLO Threshold - FB	FB Ramping Down (AP2014)	0.4	0.6	0.8	V
		FB Ramping Down (AP2014A)	0.3	0.4	0.5	V
	UVLO Hysteresis - FB	-	0.1	-	V	
Supply Current						
Operation I _{CC}	V _{CC} Operation Supply Current	Freq=200KHz, C _L =1500pF	-	7	10	mA
Operation I _C	V _C Operation Supply Current	Freq=200KHz, C _L =1500pF	-	7	10	mA
I _{CCQ}	V _{CC} Static Supply Current	SS=0V	-	3.3	6	mA
I _{CQ}	V _C Static Supply Current	SS=0V	-	1	4.5	mA
Soft-Start Section						
SS _{IB}	Charge Current	SS=0V	10	20	30	µA
Error Amp						
I _{FB1}	FB Voltage Input Bias Current	SS=3V, FB=1V	-	-0.1	-	µA
I _{FB2}	FB Voltage Input Bias Current	SS=0V, FB=1V	-	-64	-	µA
gm	Transconductance		450	600	750	µmho
Oscillator						
Freq	Frequency	AP2014	170	200	230	KHz
		AP2014A	340	400	460	
V _{RAMP}	Ramp-Amplitude Voltage		1.225	1.25	1.275	V
Output Drivers						
T _r	Rise Time	C _L =1500pF	-	50	100	ns
T _f	Fall Time	C _L =1500pF	-	50	100	ns
T _{DB}	Dead Band Time		50	150	250	ns
T _{ON}	Max Duty Cycle	FB=1V, Freq=200KHz	85	90	95	%
T _{OFF}	Min Duty Cycle	FB=1.5V	0	0	-	%

Typical Performance Characteristics

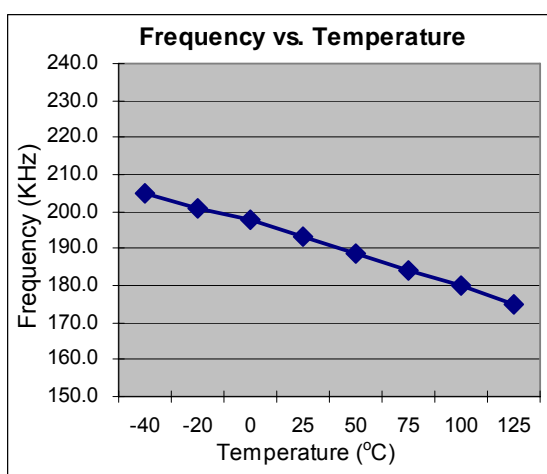
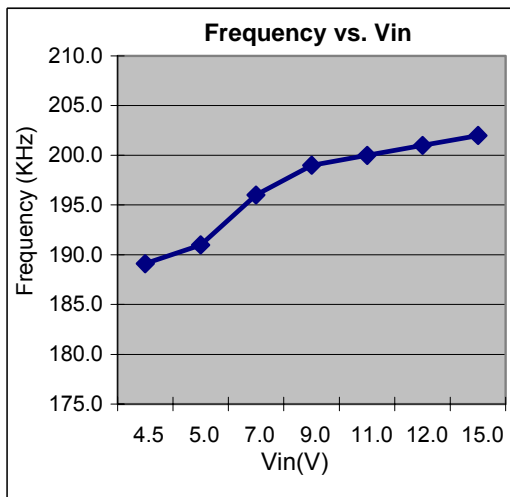
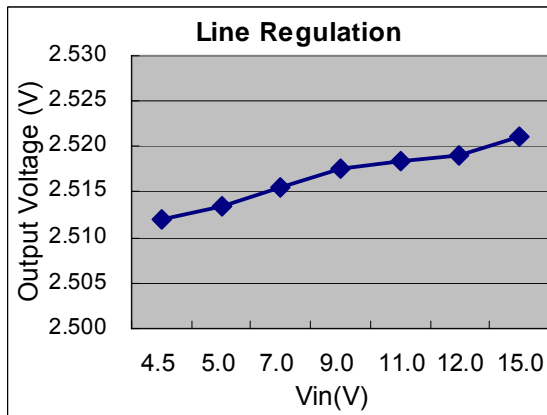
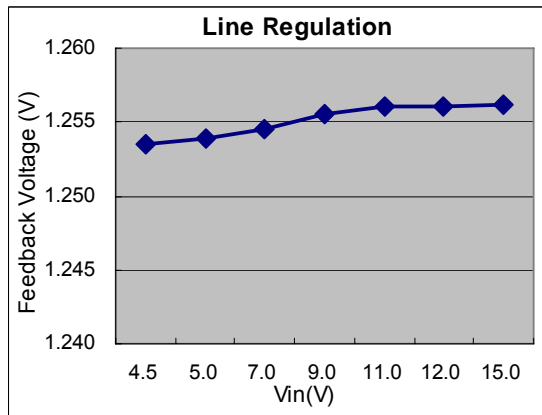
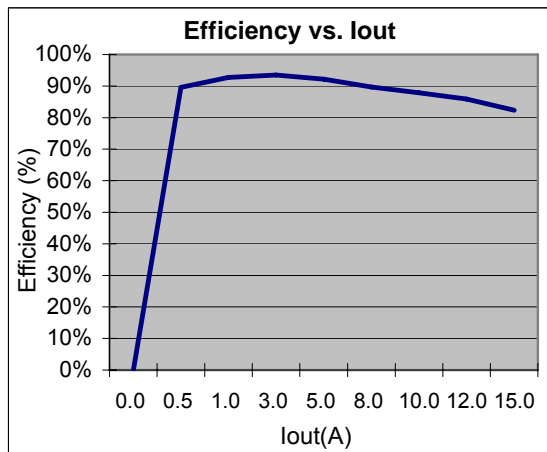
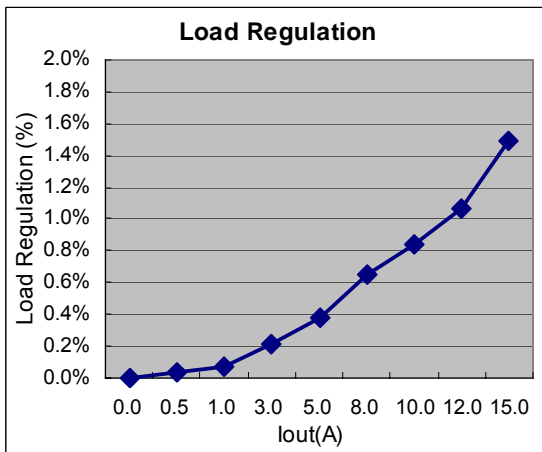

Typical Performance Characteristics (Continued)

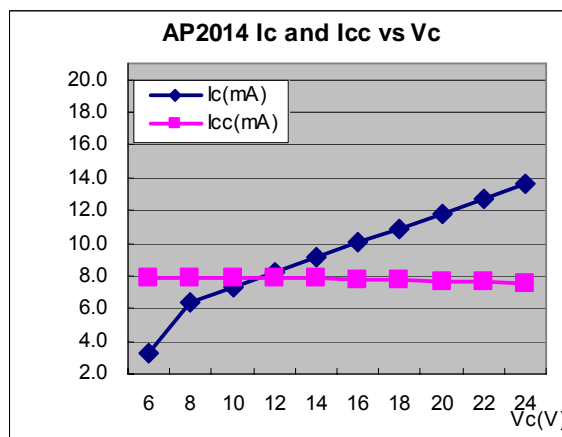
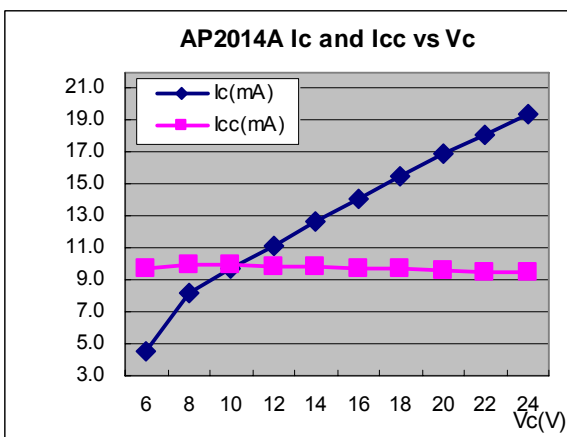
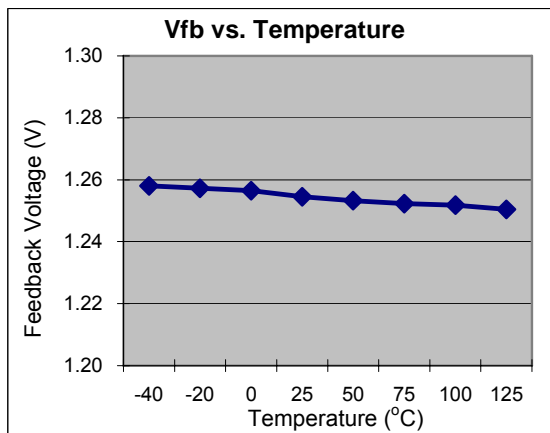
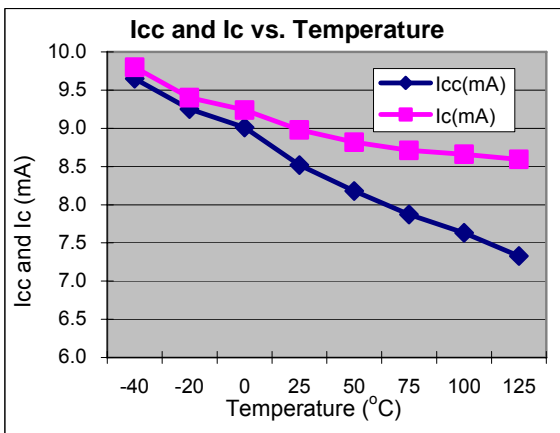
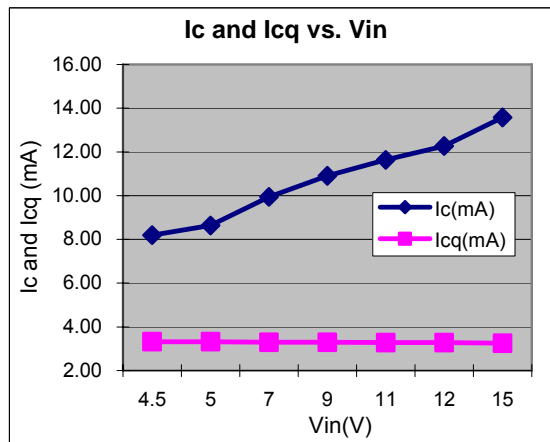
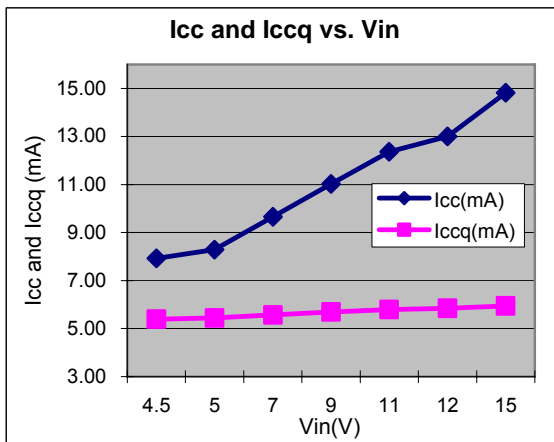

Typical Performance Characteristics (Continued)

Vout Ripple
Vcc=5V; Vc=12V; Vout=2.5V
Iout=0.5A, Vripple=30.8mV

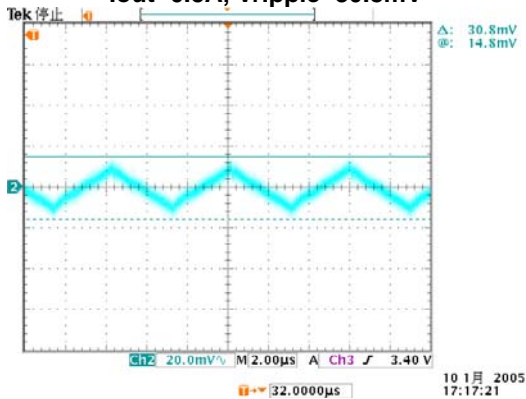

Vout Ripple
Vcc=5V; Vc=12V; Vout=2.5V
Iout=5A, Vripple=33.2mV

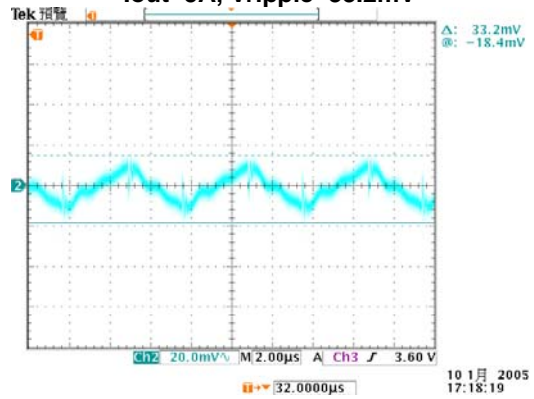

Dead time vs. Iout
Vcc=5V, Vc=12V, Vout=2.5V, Iout=0.5A, Temp=28°C

Dead time = 150ns

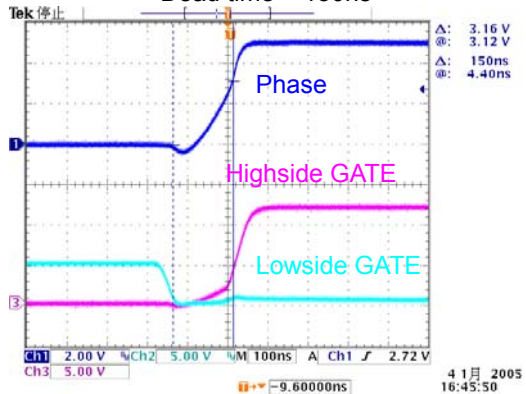

Dead time = 150ns

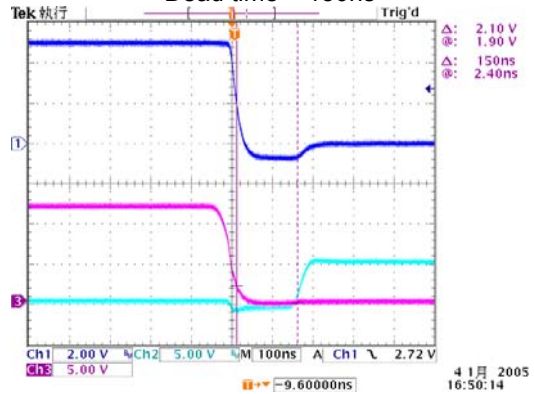

Dead time vs. Iout
Vcc=5V, Vc=12V, Vout=2.5V, Iout=5A, Temp=28°C

Dead time = 160ns

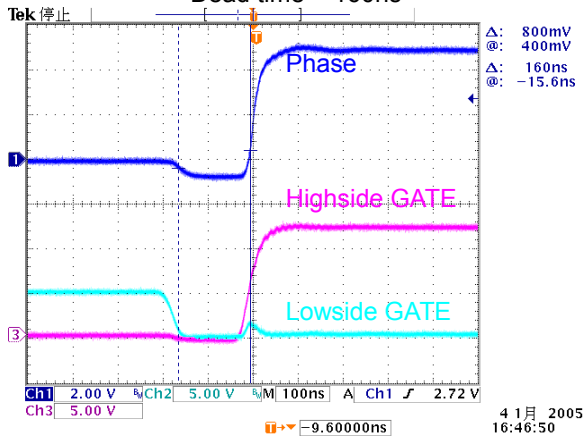

Dead time = 150ns

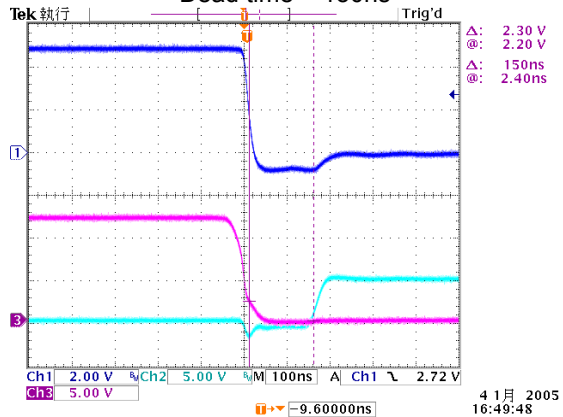

Function Descriptions

Introduction

The AP2014 is a fixed frequency, voltage mode synchronous controller and consists of a precision reference voltage, an error amplifier, an internal oscillator, a PWM comparator, 0.5A peak gate driver, soft-start and shutdown circuits (see Block Diagram).

The output voltage of the synchronous converter is set and controlled by the output of the error amplifier; this is the amplified error signal from the sensed output voltage and the reference voltage.

This voltage is compared to a fixed frequency linear sawtooth ramp and generates fixed frequency pulses of variable duty-cycle, which drives the two N-channel external MOSFETs. The timing of the IC is provided through an internal oscillator circuit which uses on-chip capacitor to set the oscillation frequency to 200 KHz (400 KHz for "A" version).

Soft-Start

The AP2014 has a programmable soft-start to control the output voltage rise and limit the current surge at the start-up. To ensure correct start-up, the soft-start sequence initiates when the V_C and V_{CC} rise above their threshold (3.3V and 4.2V respectively) and generates the Power On Reset (POR) signal. Soft-start function operates by sourcing an internal current to charge an external capacitor to about 3V. Initially, the soft-start function clamps the E/A's output of the PWM converter. As the charging voltage of the external capacitor ramps up, the PWM signals increase from zero to the point the feedback loop takes control.

Short-Circuit Protection

The outputs are protected against the short circuit. The AP2014 protects the circuit for shorted output by sensing the output voltage (through the external resistor divider). The AP2014 shuts down the PWM signals, when the output voltage drops below 0.6V (0.4V for AP2014A).

The AP2014 also protects the output from over-volting when the control FET is shorted. This is done by turning on the sync FET with the maximum duty cycle.

Under-Voltage Lockout

The under-voltage lockout circuit assures that the MOSFET driver outputs remain in the off state whenever the supply voltage drops below set parameters. Lockout occurs if V_C and V_{CC} fall below 3.3V and 4.2V respectively. Normal operation resumes once V_C and V_{CC} rise above the set values.

IC Quiescent Power Dissipation

Power dissipation for IC controller is a function of applied voltage, gate driver loads and switching frequency. The IC's maximum power dissipation occurs when the IC operating with single 12V supply voltage ($V_{CC}=12V$ and $V_C \approx 24V$) at 400KHz switching frequency and maximum gate loads.

Page 8 shows voltage vs. current, when the gate drivers loaded with 1500pF capacitors. The IC's power dissipation results in an excessive temperature rise. This should be considered when using AP2014A for such application.

Marking Information

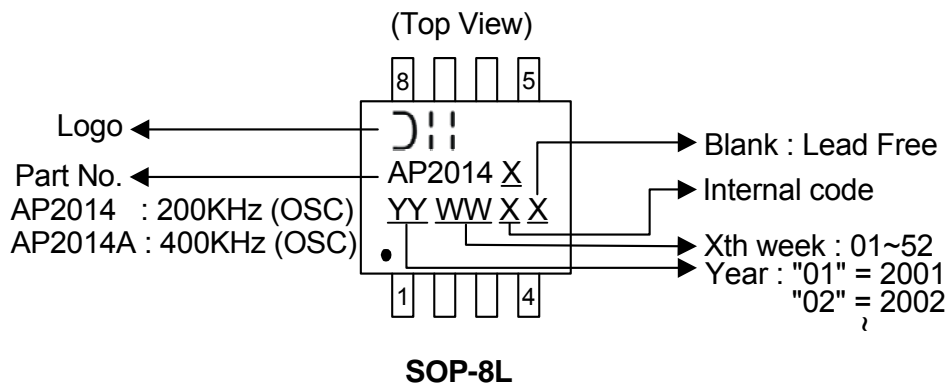

Package Information (All Dimensions in mm)

(1) Package Type: SOP-8L

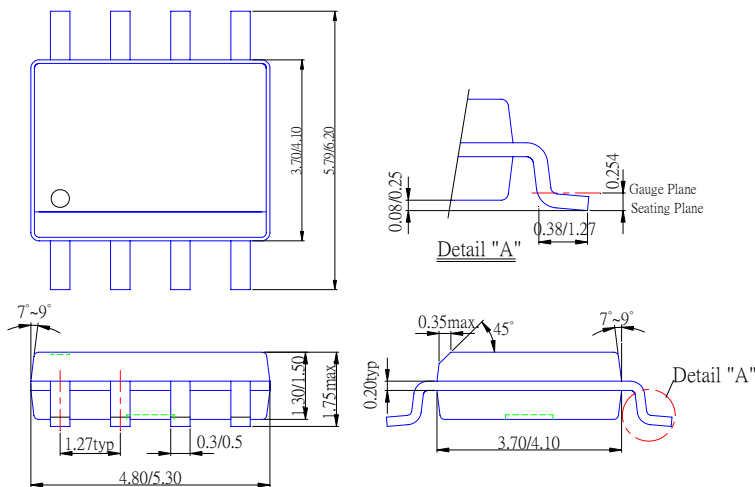

IMPORTANT NOTICE

Diodes Incorporated and its subsidiaries reserve the right to make modifications, enhancements, improvements, corrections or other changes without further notice to any product herein. Diodes Incorporated does not assume any liability arising out of the application or use of any product described herein; neither does it convey any license under its patent rights, nor the rights of others. The user of products in such applications shall assume all risks of such use and will agree to hold Diodes Incorporated and all the companies whose products are represented on our website, harmless against all damages.

LIFE SUPPORT

Diodes Incorporated products are not authorized for use as critical components in life support devices or systems without the expressed written approval of the President of Diodes Incorporated.